

J[®]
92 *S*

A Fast, Stable and Comfortable 30-Foot Spritboat
Perfect for Daysailing, Racing and Weekending



The Thrill of “J-Sprit” Asymmetric Performance Without the Spill

Developed From a Winning Design Pedigree.

The J/92S is a high-performance, affordable 30-footer that is both manageable and comfortable for short-handed sailing as well as a fun boat on the race course. The **S** is for simple, strong, sporty, spectacular...it all adds up to a versatile 30-footer that meets the demands of today’s active sailing family. Sharing the design pedigree of the J/92, which was named “Boat of the Year” by *Sailing World* magazine, the J/92S has been optimized with an extended cockpit, deeper keel, and higher aspect non-overlapping sailplan. The result is greater performance and stability in a boat that’s easier to sail.

A Blast to Sail...Upwind and Down.

The high aspect sailplan of the J/92S generates more power and lift with less sail area. Combined with the balanced spade rudder and low VCG (vertical center of gravity) fixed keel, the J/92S sails closer to the wind than most 35-40 footers...and the 110 percent roller-furling jib is easy to trim, tack, and furl. Off the wind, the J/92S is a rocketship. The masthead asymmetrical spinnaker is flown from a retractable carbon “J sprit,” and can be jibed from the cockpit. In fact, two people can set, jibe, and take down the spinnaker in complete control.



“I absolutely love this boat. It feels good on all points of sail, and has reinforced my love of sprit boats. Just like a J/80—lots of fun!”
Steve Spurlin, J/92S BoatName



A Yacht That's Responsive and Rewarding to Sail

Fun to Steer, Easy to Crew.

With a deep, balanced spade rudder for complete control and a bulbed, lead ballast keel for high stability and sail-carrying power, the J/92S holds its own (and more) against bigger boats. From the fingertip, dinghy-like response on the tiller to the stable feel in big waves and breeze, owners rave about how well the J/92S sails. When short-handing, you can lengthen the tiller extension and reach the cabin-top halyards and controls. And when you add more crew, there's no need to recruit the local rugby team. The J/92S is designed to be sailed by a family-and-friends crew. After all, sailing is supposed to be both fun and inclusive—and so should a good boat reward everyone on the crew, no matter their weight, strength, or sailing experience.

First-Class Layout and Equipment.

The J/92S is equipped with self-tailing primary winches, adjustable jib leads, and double-ended backstay and traveler control lines. The mainsheet system, with swivel base cam, ratchet block, and fine-tune trim, allows the driver to easily tinker without bothering the crew. Headsail and spinnaker-handling gear, including coachroof-mounted triple rope clutches and two-speed halyard winches, is located so that each person can work efficiently, whether cruising shorthanded or as a part of a full crew.



"We raced the Chicago NOOD Regatta two days after launching our new J/92S. Despite no practice and having only four crew, our boathandling was really good—jibing is a snap. It's amazing how easy it is to sail this boat!"

Rich Stearns, J Boats Midwest



Built for Sailors Who'd Rather Sail

No-Hassle Sailing.

Built by J/Europe to CE Mark Category "B" standards, the J/92S maximizes sailing time and minimizes maintenance. Hull and deck are molded with Lloyds-approved Baltek end-grain balsa and unidirectional and biaxial laminates, producing a light, stiff composite structure with superior impact resistance and durability. The minimal-maintenance deck (no teak) features molded-in toe-rails; cockpit footrests provide sure footing in windy conditions.

Accommodations with an Inboard Auxiliary.

The J/92S sleeps four in two-cabin privacy with plenty of ventilation and natural light; the galley, navigation area with storage, and marine head provide all the essentials for overnighting. The optional cockpit "dockbox" (shown below) is great for extra storage when cruising. And if the wind dies below 5 knots, the dependable 13-hp Volvo diesel, equipped with Saildrive and a folding two-bladed prop, will take you to the next cove or home at day's end.



J/92S Specifications

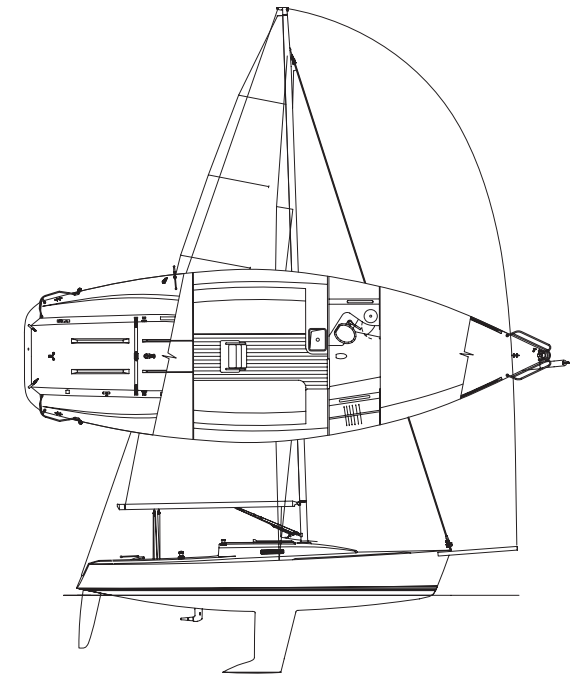

	U.S. (feet)	Metric (m)
LOA	30.00	9.14
LWL	26.70	8.14
Beam	10.00	3.05
Draft	6.24	1.90
Displacement	5,610	2,545
Lead Keel	2,317	1,051
Engine	13hp Volvo	13hp Volvo
100% Sail Area	505	46.91
IM	40.68	12.40
ISP	44.08	13.44
J	11.48	3.50
P	38.88	11.85
E	13.95	4.25
SA/Dspl	26	26
Dspl/L	131	131

Specifications are subject to change without prior notice or obligation



Box 90, 557 Thames Street, Newport, RI 02840, U.S.A.
 Tel: 401-846-8410; Fax: 401 846-4723
 Email: info@jboats.com; Web: www.jboats.com