



Sportboat Thrills with Stability
in a Family Friendly One-Design



Exciting Sportboat Performance and World-Class Competition

Friendly Sailing at Home and Around the World.

With 1200+ boats on the water and a strong class organization promoting J/80 activity in the United States, France, England, Spain, Sweden, Germany, Italy, Benelux, Denmark and other areas, the J/80 is the sportboat of choice for sailors the world over. The J/80's combination of thrilling performance and reassuring stability, tough construction and one-design popularity has attracted a wide variety of enthusiasts. Close racing, sportboat speed—under spinnaker the J/80 planes at 15+ knots—and a well-rounded, fun-to-sail design add up to enduring value. It's no wonder the International Sailing Federation (ISAF) recognizes the J/80 as an International Class.

Tight One-Design Rules and an Owner-Run Class.

Strictly-enforced one-design rules ensure that J/80 racing is always fair and close. J/80 class rules limit the number of new sails that can be purchased per year, minimizing the cost of racing, and the rules place a commonsense cap on crew weight, so that sailors of all sizes can compete successfully. The J/80 class (www.j80.org) schedules and oversees events and provides a wealth of information, from owner's forums (tuning tips and advice) to classified ads (sails, equipment, and boats for sale).



The J/80 Is Safe, Stable, and a Blast on All Points of Sail

The J/80 is Fun to Steer and Easy to Crew.

The J/80 has a balanced, instant-response helm that makes steering a true joy. The boat's 12-foot, 3-inch-long cockpit gives the rest of the crew plenty of room without needing to clamber over the cabintop during tacks and jibes; the high boom adds to safety. When you are ready for turbo-charge mode, the asymmetrical spinnaker is easy to set and fly: Pull a control line to extend the carbon-fiber J Sprit, hoist the halyard, and trim the sheet. To jibe, ease one sheet and pull in the other. There's never a need to touch the pole or step onto the foredeck—everything, even dousing the spinnaker, is done from the safety of the cockpit.

A Boat That Rewards Skill, Not Weight and Muscle.

You'll find that J/80 racing is deep with world-class sailors. And you'll also find that you won't need to recruit hired guns or bring professional sailors aboard to be able to race and win. (In fact, the winner of the 2004 J/80 World Championship raced with a family crew that included his sister and 13-year-old son.) Thanks to a fixed, bulbed lead keel the J/80 has high stability, and the boat's balanced hull shape and deep rudder means that the skipper maintains full control of the boat in every condition. The J/80's responsiveness to tuning and sail trim adjustments helps owners become faster sailors and smarter ones too!



Built to Last and Equipped with First-Class Hardware

Built Tough with a Race-Ready Layout.

The J/80 is built with Lloyds-approved Baltek end-grain balsa and E-glass structural skins, producing a composite structure with twice the impact resistance and durability of ordinary race-boat laminates—your J/80 will stand up to year after year of vigorous use. With sealed buoyancy tanks forward and under the cockpit, a closed transom, and high righting moment, the J/80 is the only production sportboat under 30 feet certified for Design Category B under the EU Recreational Craft Directive of the ISO (International Standards Organization). The J/80 is minimum-maintenance, with thermo-molded plastic toe-rails and stainless handrails. The J/80 comes race-ready with a high-performance aluminum racing mast, boom, running rigging, and Harken deck hardware.

Great for Daysails and No-Hassle Overnighting.

The J/80 sails fast and handles well under mainsail alone—perfect for solo getaways or daysails with family and friends—and using the roller-furling jib is a snap. The J/80's interior features four berths, storage areas, and a removable cabin sole. The J/80 is easily towed, taking you to a new cruising area or the venue of the national championships. And whether your weekend calls for daysailing or racing, the J/80 is always a joy to sail.



J/80 Specifications

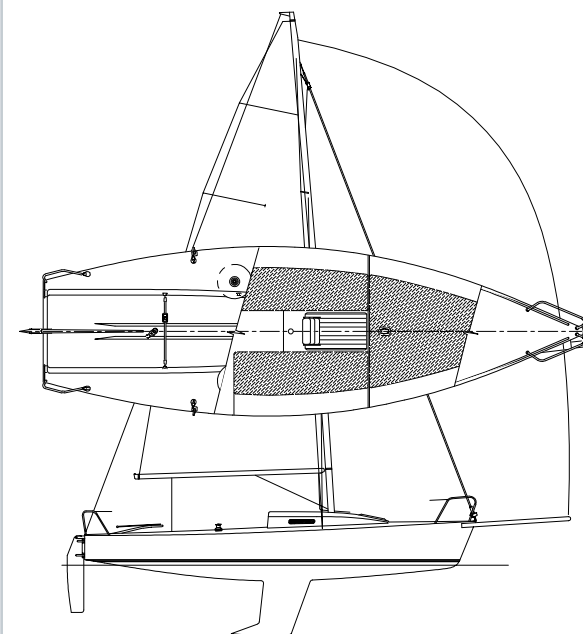

	U.S. (feet)	Metric (m)
LOA	26.30	8.00
LWL	22.00	6.71
Beam	8.30	2.51
Draft	4.90	1.49
Displacement	2,900	1,315
Ballast	1,400	635
Engine	Outboard	Outboard
100% Sail Area	338	31.40
I	31.50	9.60
ISP	33.00	10.06
J	9.50	2.90
P	30.00	9.14
E	12.50	3.81
SA/Dspl	27	27
Dspl/L	122	122

Specifications are subject to change without prior notice or obligation



Box 90, 557 Thames Street, Newport, RI 02840, U.S.A.

Tel: 401-846-8410; Fax: 401-846-4723

Email: info@jboats.com; Web: www.jboats.com